

Time Delay Relays

Plug-in Time Cubes and Time Delay Modules

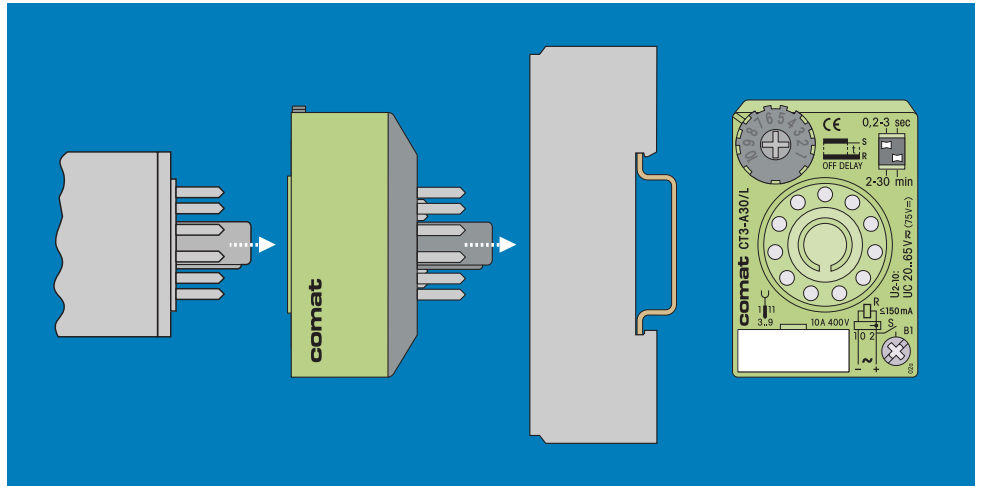

Time Cubes®: CT2 and CT3

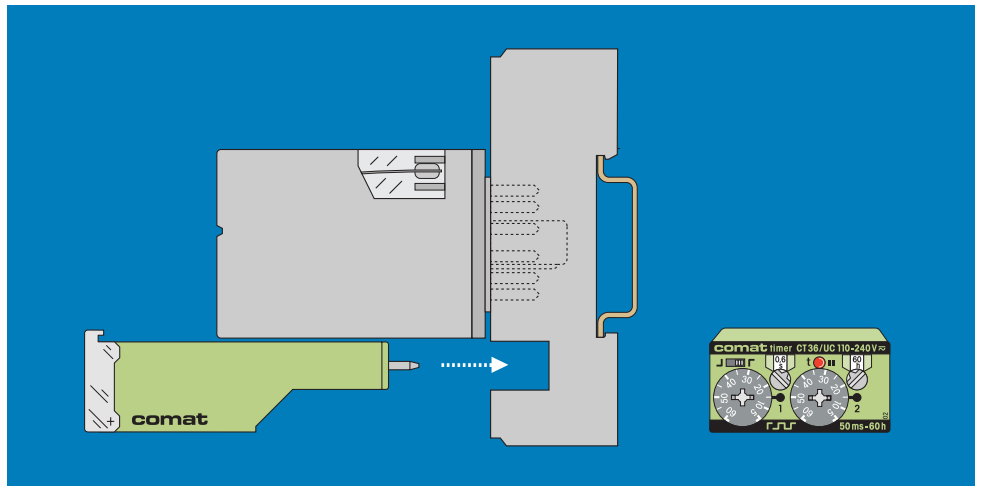

CT-System: CT30, CT32, CT33, CT36



Time Cubes

SIMPLY PLUGGED BETWEEN

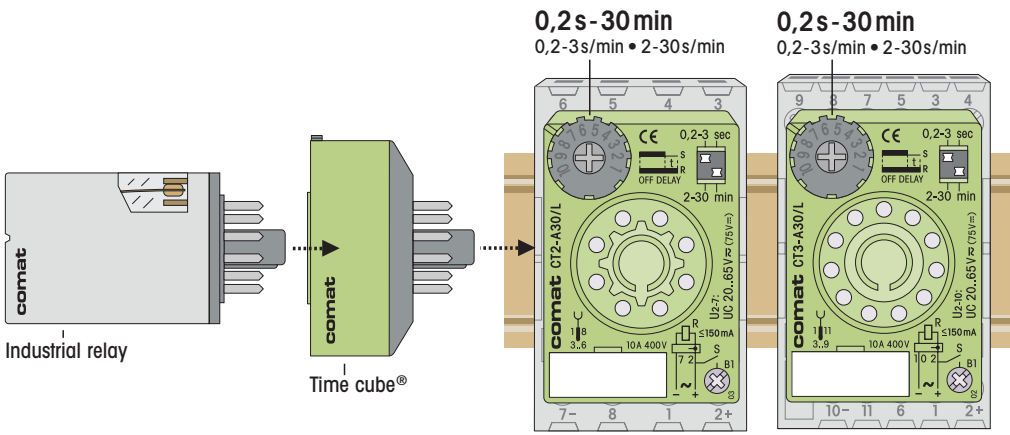

8-/11-pole Plug-in Time Delay Relay System
 The simplest time delay relay system world-wide, fitting all 8 or 11-pin relay sockets (octal/sub-magnalite). Original time cubes® are simply placed between socket and relay without rewiring.
 In this way, even as a retrofit, all industrial relays can be provided with the required timing functions without additional space being required. The contact connections of the relay on the socket remain through-connected.

All new types ..30 (0,2s-30min) are fully compatible with all previous types ..20, ..21 and ..25.



μ MAX

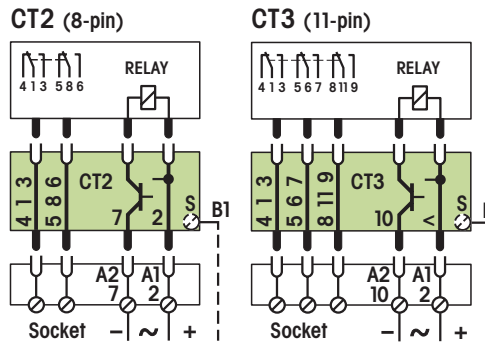

10A 250V~

On delay

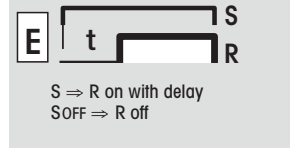

Off delay

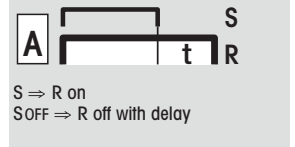

One shot leading edge

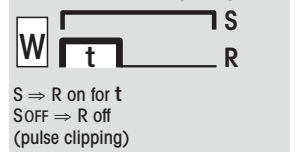

Pulse shaping

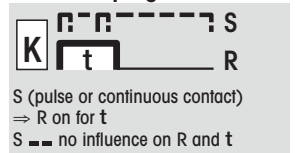

Blinker, pulse start

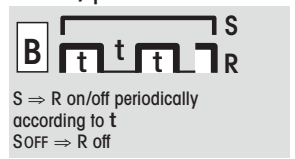

ON OFF S = Triggering
 R = Output circuit
 => = switches...

Order no.	Function	Triggering	UC180-265V	UC90-150V	UC90-265V	UC20-65V	DC9,5-18V
2 = 8-pole 3 = 11-pole	E-0	CT...-E30/...	H	L	S		
	A-2	CT...-A30/...	U	M	L	S	
	K-2 W-3	CT...-K30/...	U	M	L	S	
	W-0	CT...-W30/...	H	L	S		
	B-0	CT...-B30/...	H	L	S		

Ordering example

- Time cubes CT2-E30/H
Socket EC-8 or CS-8
- Relay C2-...
- Time cubes CT3-E30/H
Socket EC-11 oder C11A
- Relay C3-...

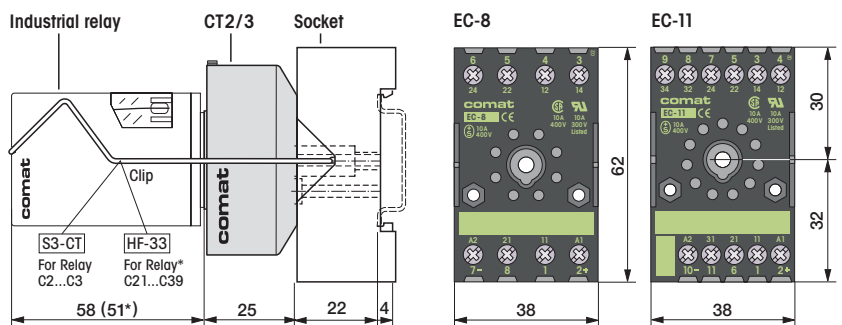



Multifunction Time Delay Relays, Modular

The Comat CT System is modular.

The time delay relays and monitoring relays consist of the plug-in CT electronic module and an 11-pole CT output relay. Both system components can be combined freely with one another. This allows the equipment to be selected optimally for specific use.

Subsequent modifications, for example a change from mechanical contacts to solid-state outputs, are possible at any time by simple reconnection. This provides the user a complete, universal system, the high flexibility of which is unique throughout the world.

The system socket C12B0 serves as a basis for the vibration-free reception of the electronic module. It has a 4-pole module slot in which the CT-module –also without output relay– locks in such a way that it is vibration-free. Contact is via twin knife contacts which ensure optimal contact reliability.

With the A2-connector C-A2 plug-in flush in the socket, the neutral conductor (N / -) can be connected as a 10A bus from socket to socket. This considerably reduces wiring work.

Robust terminals for cross-sections up to 4mm² and generous labelling facilities are other advantages of this practical comat system socket. As variants to the standard socket C12B0, two identical sockets, but with printed device diagram, are available (C12B1/2). By clearly identifying the connections, these sockets ensure rapid, error-free and therefore economical wiring. When a service is required, they facilitate fault location.

The CT module demonstrates comat's practical experience in the area of industrial electronics. All control and display elements are arranged on the front and are labelled in a self-explanatory manner for international use. The values set are also clearly legible when the module has been installed.

Printed diagrams explain the functions, and the connection scheme directly indicates the appropriate terminals in the system socket.

A transparent front cover provides protection from unauthorized misadjustment and additionally locks the module onto the output relay.

Triggering is performed with the operating voltage (L1 or +). Hence, no potential-free contacts are required. Triggering complies with the machine standards. A parallel connection of other users to B1 is admissible.

The 2 voltage ranges UC110-240V and UC24-48V have been chosen by comat to ensure a high level of reliability in triggering. They permit use with an AC or DC supply and optimal adaptation to the operating conditions of modern controls.

In case of an even broader voltage range, e.g. 24-240V it is often possible to achieve only currents of a few 100µA in the trigger circuit B1 with simultaneous low threshold voltages to less than 20V. This may lead to unintentional triggering due to capacitive/inductive pickups, or faulty switching may occur owing to sufficiently loaded control contacts. During operation, 50V are readily measured on open-ended lines.

The consumption of the CT modules comes to less than 1W.

The output relays have the complete device diagram, the performance data and the complete order no. on the front, supported by a colour code, which indicates an AC coil with red and a DC coil with blue. The .1 and .2 relays have a safety manual operation facility as a standard feature, which switches the contacts only after a lock has been released (two-hand principle).

The standard contacts .1 and .3 have proved their worth millions of times in heavy current applications. The contact material AgNi permits a large switching range and thanks to generous dimensioning achieves a high number of cycles. With its high breaking capacity of up to 10A/400V, this contact is a reliable allround contact for use both in mains circuits and in the lower voltage range from 12V/10mA.

The twin contacts .2 and .4 switch every circuit with two independent reeds. Compared with single contacts, they provide up to 100 times greater safety with regard to the level of possible faulty switchings. In spite of their high breaking capacity of up to 6A/250V, these contacts are particularly suitable for low switching currents and switching voltages down to 1mA/6V.

The solid-state relays are used instead of mechanical contacts. In the standard version .5, the relay has a potential-free output which switches an AC or DC load in the same way as a mechanical contact. However, it functions without bounce or wear, withstands overloads, has short-circuit protection and has a practically unlimited life even with full output load.

Preferred applications are high switching frequency, for example as repeat cycle timers, flashing bars with bulb load or extreme inductive loads, for example large solenoid valves, couplings, motors, etc.

An additional protective wiring of the output or of the load is not necessary in these comat relays for any application.

They are completely insensitive in an aggressive atmosphere, for example in the chemical industry, in waste water treatment plants, etc.

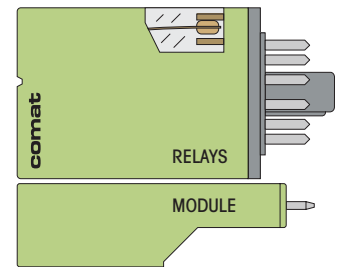
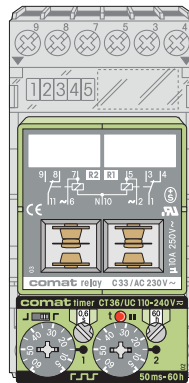

Triggering

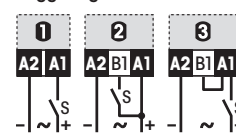

Timer module	Function/triggering	Time range
CT30 Economy timer 3 functions, voltage controlled, output LED. Seismic approved.	E W B 0	0,25 s - 30 min 0,25-3 s... 2,5-30 min
CT32 Universal timer 7 functions, voltage controlled, time lapse display, blinking. Seismic approved.	E 2 3 A N K B1 2 W B 3	0,15 s - 60 min 0,15-1,5 s... 6-60 min ★
CT33 Universal timer 12 functions, voltage controlled, time lapse display, blinking, high setting accuracy by dial graduation 1:5.	E 2 3 A N L F K G B1 W H B 3	30 ms - 60 h 30-150 ms... 12-60 h ★
CT36 Universal repeat cycle timer Pulse or pause start. t1/t2 separately settable. Time lapse display t1/t2.	I P 0	2 x 50 ms - 60 h 2 x 50-600 ms... 5-60 h ★

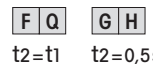

E 0 Triggering
Function (page *)

★ TF60 setting (page *)

Note on use

According to the standards «Safety of machines» e.g. EN 60204-1, EN 292-2, triggering with A2-potential (N/-) is only admissible in exceptional circumstances.

For that reason the comat CT modules are triggered by A1-potential (L/+).

This makes them unrestrictedly suitable also for use in machines and systems which must conform with machine or CE guidelines or directives.

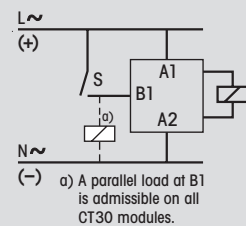

Order no. for individual module (without output relay):

UC110-240V	UC115V, UC230V	UC115V, UC230V	UC110-240V
UC24-48V	UC24-48V	UC24-48V	UC24-48V
CT30 / ...V	CT32 / ...V	CT33 / ...V	CT36 / ...V



Time Delay Relay assembled (module + output relay)

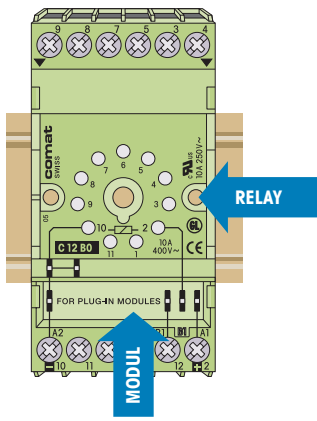

RELAY

MODUL

MAX

Contact outputs

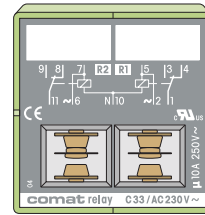
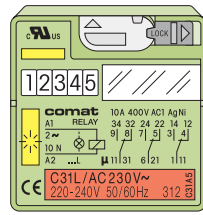
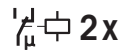
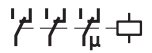

.1 RELAY: C31L/...
3 changeover cont.
10A 250V~ 1)

.3 RELAY: C33/...
2x1 changeover cont.
(with instan.t.contact)
10A 250V~ 2)

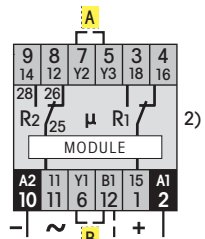
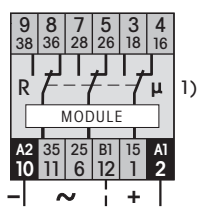

Solid-state outputs

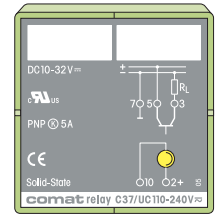
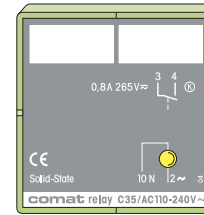

.5 RELAY: C35/...
Solid-state output
for AC or DC load
0,8A 10-265V~

.7 RELAY: C37/...
Solid-state output
for DC load
5A 10-30V==

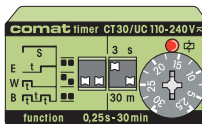
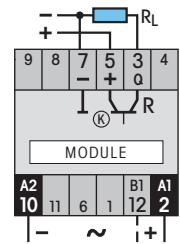
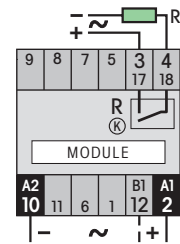

Order no.

Order no. for module + output relay (delivery unit):

AC 24, 48, 115, 230V
DC 24, 48, 110, 220V
CT30.1/...V

AC 24, 48, 115, 230V
DC 24, 48, 110V
CT30.3/...V

Order no. for module + output relay (delivery unit):

AC110-240V
UC24-48V
CT30.5/...V

UC110-240V
UC24-48V
CT30.7/...V

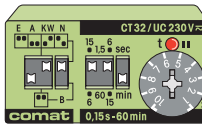

Order no.

AC 24, 48, 115, 230V
DC 24, 48, 110, 220V
CT32.1/...V

AC 24, 48, 115, 230V
DC 24, 48, 110V
CT32.3/...V

AC115, 230V
UC24-48V
CT32.5/...V

UC115, 230V
UC24-48V
CT32.7/...V

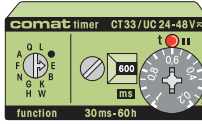

Order no.

AC 24, 48, 115, 230V
DC 24, 48, 110, 220V
CT33.1/...V

AC 24, 48, 115, 230V
DC 24, 48, 110V
CT33.3/...V

AC115, 230V
UC24-48V
CT33.5/...V

UC115, 230V
UC24-48V
CT33.7/...V

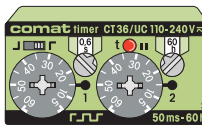

Order no.

AC 24, 48, 115, 230V
DC 24, 48, 110, 220V
CT36.1/...V

AC 24, 48, 115, 230V
DC 24, 48, 110V
CT36.3/...V

AC110-240V
UC24-48V
CT36.5/...V

UC110-240V
UC24-48V
CT36.7/...V

A Jumper 5-7 : R2 = R1
B Jumper 6-12 : R2 = S

AC 50/60Hz UC AC/DC DC 10%

The Time Relays CT30..., CT32..., CT33... and CT36... consist of modules (incl. cover) and output relays. The socket has to be ordered separately.

The modules can also be combined with other Comat relays. In this case the relays and the modules have to be ordered separately.

Please refer to chapter industrial relays for datas..

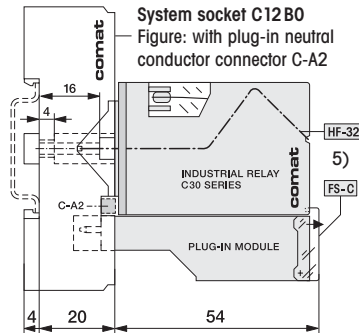
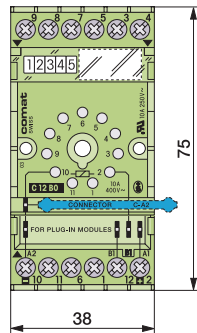

Please refer to chapter Industrial Relays for relay datas.

- 1) Same relay, but with twin contacts 6A 250V~ order no. CT...2/...V
- 2) Same relay, but with twin contacts 5A 250V~ order no. CT...4/...V
- 3) To module CT30 (Relay without output LED)
- 4) To module CT32 ÷ 36 (L = Relay with output LED)
- 5) For relay C3... (instead of C31/32, or CT...1/.2): Retaining clip S3-C Front cover FS-R

Ordering example

Timer CT32.1/AC230V
Socket C12B0

Order no. for individual output relay (without module):

AC 24, 48, 115, 230V
DC 24, 48, 110, 220V
C31/...V³⁾ C31L/...V⁴⁾ C33/...V

AC110-240V
UC24-48V
C35/...V

UC110-240V
UC24-48V
C37/...V